

hydrocarbon solvents under their own vapor pressure show liquid-liquid immiscibility above a lower critical solution temperature (LCST) which can be well below the critical point of the solvent. Such a LCST is the intersection of the vapor pressure surface with the critical locus and has been termed a lower critical end point (LCEP). A LCST generally occurs at a pressure near this point, i.e., the critical locus has a positive slope.

The solution of polymers in gases at high pressures is a possible subject for future research.

The work to be reported explores this connection further and provides data on the conditions of solubility of polyethylene in *n*-alkane solvents above and below their critical temperatures. The data will be seen to show the general trends in the critical loci of binary alkane systems as the components assume extreme size differences.⁵

EXPERIMENTAL

Equipment

Figure 1 describes the experimental arrangement. The optical bomb is supported inside a brass ring linked by a worm gear to a synchronous motor. It could be rocked automatically around the horizontal position in a plane perpendicular to the axis through either set of windows, or it could be positioned at any desired angle. The bomb was connected by an arm of $1/4 \times 1/16$ in. tubing (B) and a coil (D) made of $1/8 \times 0.020$ in. tubing, with its plane parallel to the plane of rotation of the bomb, to the

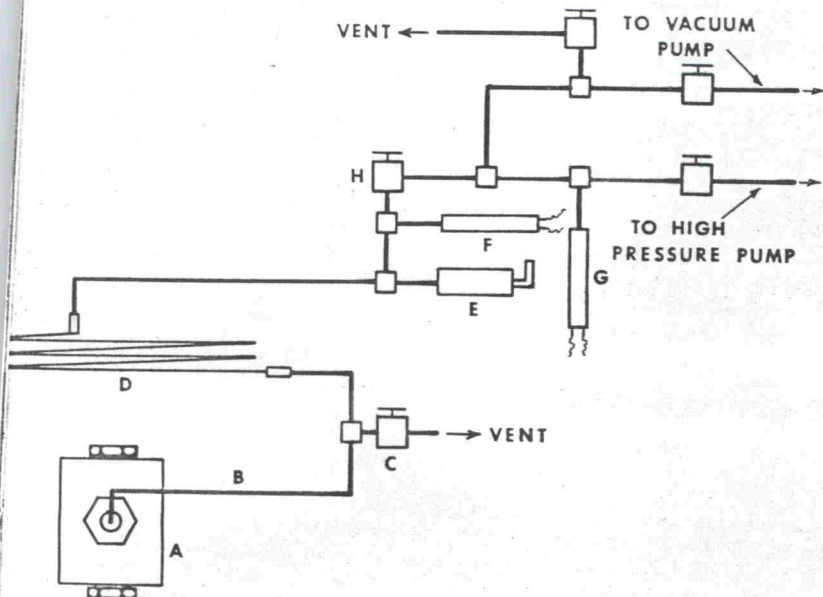

Fig. 1. Experimental arrangement.